

TSC-600C-BLK

DATA SPECIFICATION SHEET



CATEGORY: CONCRETE

COLORS: ●

PRODUCT OVERVIEW

Concrete 6" Step Light — TSC-600C-BLK

The Tru-Scapes Concrete 6" Step Light TSC-600C is a durable and modern lighting solution designed for installation in concrete, paver, or stone applications. Its 6" size and color-changing LED capabilities make it ideal for illuminating steps, pathways, and patios. Built with energy-efficient technology and robust materials, the TSC-600C provides both style and functionality for enhancing outdoor spaces in residential and commercial settings.



Scan to Visit Our Website!

SPECIFICATIONS

- Construction: Powder Coated Aluminum
- Finish: Black
- Light Source: Integrated RGB LEDs
- Watts: 1.5W
- Beam Angle: 180
- Color Temp (CCT):
 - RGBCW (2700K – 6500K)
- Lumens: 8
- Power Factor: 1.56
- Voltage Range: 9v - 15v AC/DC
- Powered By: 12V Low Voltage Transformer (Sold Separately)
- Dimensions: L 6" x W 2-3/4" x D 1-1/8"
- IP65 Rated

FEATURES & BENEFITS

- The larger size is perfect for illuminating steps, pathways, and outdoor areas while blending seamlessly into concrete surfaces.
- features integrated Color changing LED technology that delivers bright light with minimal energy consumption.
- features a weatherproof design, ensuring they withstand exposure to rain, wind, and other outdoor elements.
- Made from durable aluminum and finished in black, the TSC-600c offers a modern, sleek look for any design.
- Low energy consumption - Low Voltage LED Design.

PRODUCT DIMENSIONS

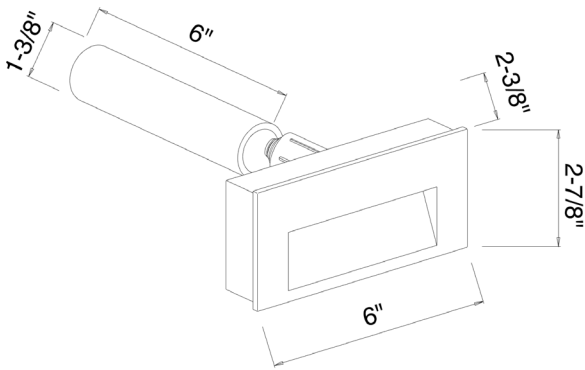

WARRANTY

- Tru-Scapes Lighting Sockets have a Lifetime Warranty.
- Light fixtures of brass, copper or stainless steel, aluminum, including finishes are warranted for five (5) years.
- LED Bulbs are warranted for five (5) years or 30,000 hours, whichever comes first.
- Stainless Steel, Painted and Weatherproof (plastic housing) transformers, excluding timers and photo cells, are warranted for five (5) years for the original purchaser.
- Tru-Scapes warranties do not cover plants that die or burn because of continuous light shined on them. This is not a defect, but the inherent nature of such plants. Certain acid loving plants such as arborvitae, pine trees, and others must not be exposed to light of any kind for more than 18 hours a day as these plants need time to sleep and allow photosynthesis to naturally occur.
- Low voltage landscape lighting fixture housings made of brass do naturally patina in color which is not a defect. (Please see www.Tru-Scapes.com for cleaning instructions.)
- See our full Warranty details at www.Tru-Scapes.com/faq.

CERTIFICATIONS



Indicates the product meets safety standards tested by Intertek.



Signifies the product has passed safety tests by Underwriters Laboratories.



Ensures the product is dust-tight and highly water-resistant.

CONTACT US

© Copyright 2024,
Tru-Scapes® Registered Trademark•
Bucks County, PA • All Rights Reserved•
contacts@tru-scapes.com
1-800-878-1240

WWW.TRU-SCAPES.COM

